

QW型 QB型
DQW型 DQB型

本厂已通过GB/T19001-2008质量管理体系认证
Factory has passed GB/T19001-2008 Quality System Certification

部分回转阀门电动装置 PARTIAL ROTARY VALVE ELECTRIC DEVICE

INS
TRUC
TION

使
用
说
明
书



常州市精迪阀门控制有限公司
Changzhou Jingdi Valve Control Co. Ltd.



常州市精迪阀门控制有限公司
Changzhou Jingdi Valve Control Co. Ltd.

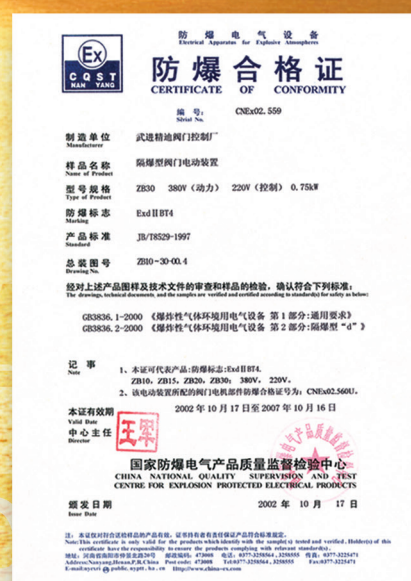
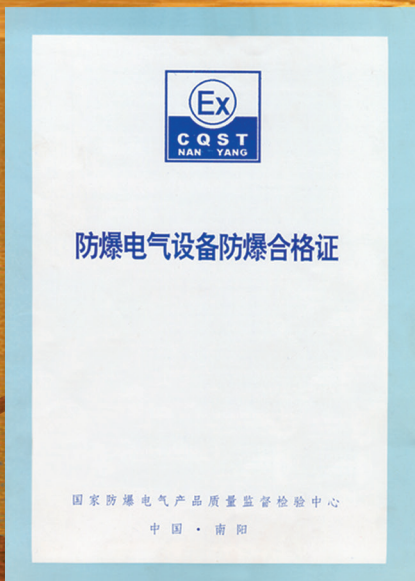

1、概述

QW、QB、DQW、DQB为部分回转型阀门电动装置,QW、QB为整体式,DQW、DQB为叠加式(Z型电装加二级减速器)。适用于蝶阀、球阀、旋塞阀和风门挡板等做90°回转的阀门。用于控制阀门的开启和关闭,可远距离控制,也可现场操作。广泛地用于电力、冶金、石油、化工、食品、纺织、造纸、制药、水厂和污水处理等部门。

按使用环境分:QW、DQW为户外型;QB、DQB为防爆型。

2、型号表示方法

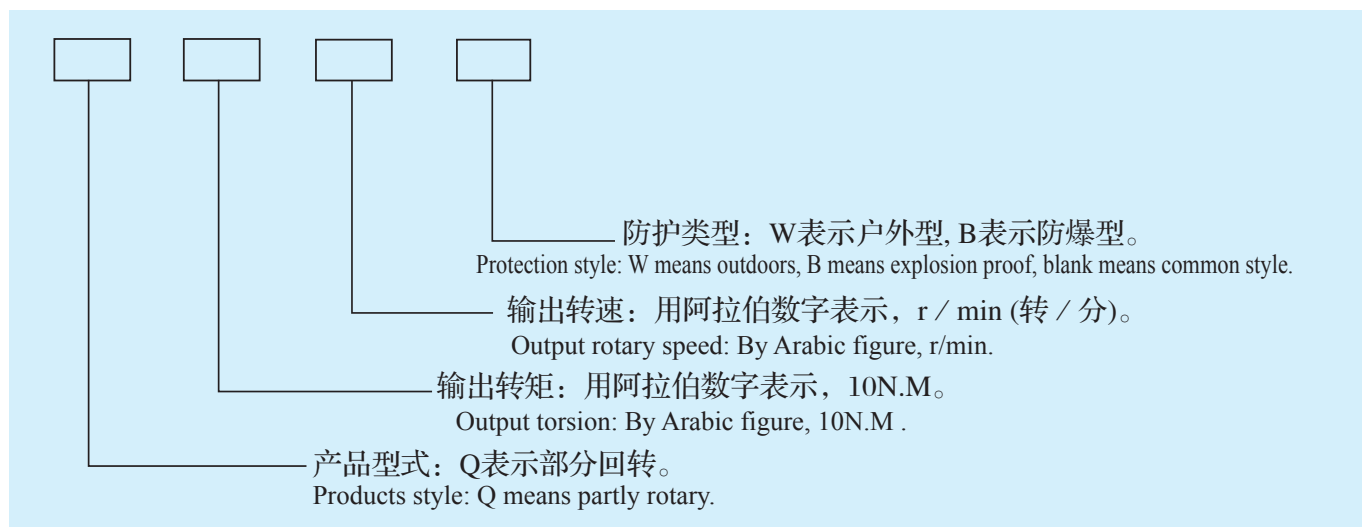

型号示例

- 1)Q10-1B表示整体式部分回转,输出转矩100N·m,输出转速1r/min,防爆型。
- 2)DQ8000-0.35W表示叠加式部分回转,输出转矩80000N.m,输出轴转速0.35r/min,户外型。

3、工作环境和主要技术数据

3.1、电源:电机为三相交流,380V,50Hz;控制线为220V,50Hz。(特殊电源订货时注明)

3.2、工作环境:

3.2.1、环境温度: -20~+60℃

3.2.2、相对湿度: ≤90%(25℃时)

3.2.3、普通型和户外型用于无易燃、易爆和腐蚀性介质的场所;防爆型用于含有爆炸性气体或爆炸性物质的场所,防爆型标志有d I(适用于煤矿非采掘工作面)和d II BT4(适用于工厂);

3.2.4、防护等级:户外型和防爆型为IP55;

1.Brief Introduction

QW, QB, DQW, DQB are partly rotary valve electric actuator. Q means complete style. DQ means superposition style. (Z style is equipped with second reducer). They are applied for butterfly valve, ball valve, plug valve and air-gate baffle 90 degree rotary valve. It can control valve switch on/off, for remote control or site operation. It's widely used in many industries such as power, metallurgy, petroleum, chemical, food, textile, paper, medicine, water plant and effluent treatment, etc.

Divided by environment: QW and DQW for outdoors. QB and DQB for explosion proof.

2.Style explanation

For example:

- 1)Q10-1B: It means complete style with partly rotary. The output torsion is 100N.M. Output rotary speed is 1r/min. Explosion proof style.
- 2)DQ8000-0.35W: It means superposition style with partly rotary. The output torsion is 80000N.M. Output rotary speed is 0.35r/min. Outdoors style.

3.Working environment and technical data

3.1.Power: Three phase alternating motor, 380V/50Hz. Control wire is 200V/50Hz (Special power available before place order)

3.2.Working environment:

3.2.1.Environment temperature: From-20 to +60℃

3.2.2.Relative humidity: Less than 90% (under 25℃)

3.2.3.The common and outdoors style is applied for no inflammable, explosive and corrosion location. Explosion proof style is applied for location where there is explosive gas or material. Explosion proof style is marked with d I (Applied for non-excavate working place of coal mine) and d II BT4(Applied for factory)

3.2.4.Protection grade: IP55 for outdoors style and explosion proof style

3.3工作制：为短时10分钟。

3.4型号规格和性能见表 1。

3.3 Working regulation: Short time with specified working duration 10 minutes.

3.4 Characteristics specification (Tabulate 1)

表1、QW、QB和DQW、DQB型电装的主要性能
Tabulate 1 Characteristics specification for Q and DQ style electric valve actuator

型号 Style	输出转矩 Output torsion (N·m)	输出转速 Output rotary speed (r/min)	最大阀 杆直径 Max. valve shaft Dia. (mm)	叠加减速器 Superposition reducer		电装Z型 电装型号 Electric actuator style equipped with Z style	电动机 Motor		手动速比 Manipulating ratio	参考 重量 Referenced Weight	备注 Remarks
				型号 Style	速比 Ratio		功率 Power (KW)	额定电流 Specified current (A)			
QW QB 5	50	1	22	/	/	/	0.03	0.3	88		
		2					0.06	0.48			
QW QB 10	100	1		/	/	/	0.06	0.48			
		2					0.09	0.60			
QW QB 20	200	1	28	/	/	/	0.09	0.60			
		2					0.12	0.70			
QW QB 30	300	1		/	/	/	0.12	0.70			
		2					0.18	0.95			
QW QB 60	600	1	42	/	/	/	0.18	0.95	74		
		2					0.25	1.30			
QW QB 90	900	1	50	/	/	/	0.25	1.30			
		2					0.37	1.6			
QW QB 120	1200	1		/	/	/	0.37	1.6			Integrating Style
		2					0.55	2.4			
QW QB 200	2000	0.5	/	/	/	0.37	1.6				
		1				0.55	2.4				
QW QB 250	2500	0.5	60	/	/	/	0.55	2.4	67		
		1					0.75	3.0			
QW QB 300	3000	0.5		/	/	/	0.55	2.4			
		1					0.75	3.0			
QW QB 400	4000	0.5	/	/	/	0.55	2.4				
		1				0.75	3.0				
QW QB 500	5000	0.5	/	/	/	0.75	3.0				
DQW DQB 500	4000	0.375	80	JW120	48	Z30-18/20	0.55	2.4	48	Adding Style	叠 加 式
DQW DQB 600	6000	0.375	80	JW120	48	Z30-18/20	0.55	2.4	48		
DQW DQB 800	8000	0.44	100	JW150	54	Z45-24/20	1.1	3.4	54		
DQW DQB 1000	10000	0.44	100	JW150	54	Z60-24/20	1.5	4.5	54		
DQW DQB 1200	12000	0.44	100	JW150	54	Z60-24/20	1.5	4.5	54		
DQW DQB 1600	16000	0.40	120	JW180	60	Z60-24/20	1.5	4.5	60		
DQW DQB 2000	20000	0.40	120	JW180	60	Z90-24/20	2.2	6.5	60		
DQW DQB 3200	32000	0.35	160	JW280	68	Z120-24/20	3.0	9	68		
DQW DQB 4000	40000	0.26	160	JW280	68	Z180-18/20	4.0	11	1700		
DQW DQB 6000	63000	0.26	160	JW400	68	Z250-18/20	5.5	14	1700		
DQW DQB 8000	80000	0.26	160	JW400	68	Z250-18/20	7.5	19	1700		

4、结构

4.1、整体式结构

QW和QB型电装由阀门专用电机、减速器、行程控制机构、转矩限位机构、开度指示机构、手轮、机械限位机构等组成。QB是在QW的基础上增加了隔爆面，采用了隔爆接线盒和隔爆型电动机。QB的具体结构见图1

4.Structure

4.1.Complete style structure

QW and QB style electric actuator is made up of parts as following: Motor, reducer, traveling control system, torsion limit system, open range indicator, hand wheel, mechanical limit structure. Based on QW style, there are explosion isolation wall in QB style which is equipped with explosion isolation box and motor. (The detailed structure is shown in Drawing 1)



图1.QB防爆型电装的结构

Drawing 1 QB Explosion proof style electric actuator structure

4.2、DQ叠加式的结构

DQ型电装由本公司生产的Z型电装加二级减速器组成。按其使用的ZW型电装,分为DQW户外型; DQB防爆型(用ZB的防爆型)。

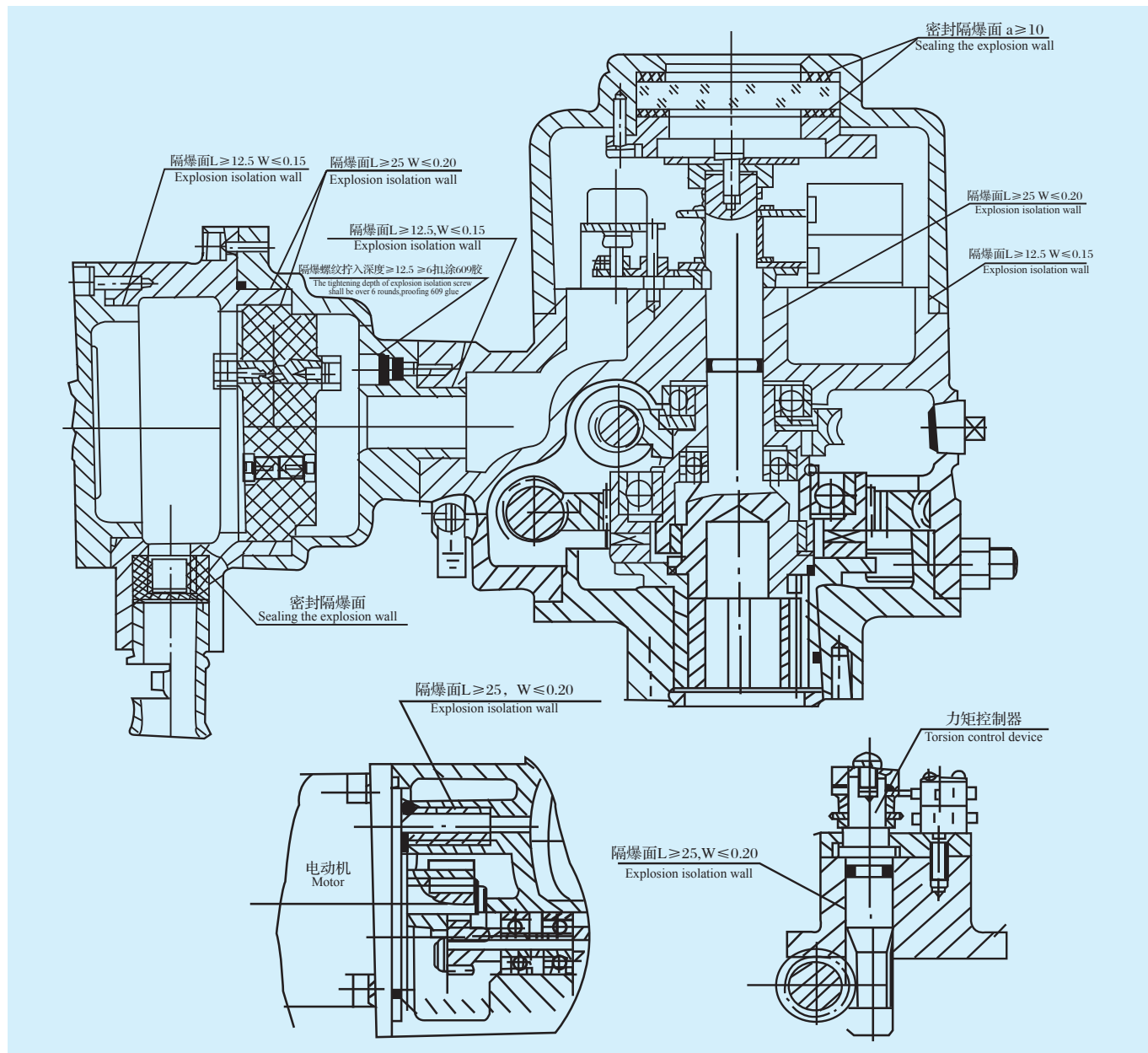
4.2.DQ superposition style structure

The DQ electric actuator is equipped with second reducer based on Z style electric actuator. There are two types based on different Z style electric actuator: DQ common style for indoors (With Z common style). DQW outdoors style (With Z outdoors style); DQB explosion proof style (With Z explosion proof).

5、外形和连接尺寸

5.1、外形和外形尺寸

5.1.1、QW、QB的外形和外形尺寸见图2和表2

表 2 . QW.QB的外形尺寸
Tabulate 2 QW,QB Configuration size

型号 Style	尺寸 Size	B1	B2	B3	H	L	L1	L2	ØD
QW	10 30	211	100	150	216	420	253	70	200
QB	10 30	300	100	250	247	420	253	70	200
QW	60 120	256	150	195	235	550	330	110	360
QB	60 120	346	150	295	282	550	330	110	360
QW	200 500	286	180	225	298	625	365	150	500
QB	200 500	376	180	325	330	625	365	150	500

5.Configuration and connection size

5.1.Configuration and configuration size

5.1.1.QW, QB Configuration and configuration size is shown in Drawing 2 and Tabulate 2



图2.QW的外形图
Drawing 2 QW Configuration



图 3 .DQW的外形图
Drawing 3 DQW Configuration

5.1.2 DQW、DQB的外形和外形尺寸见图3和表3

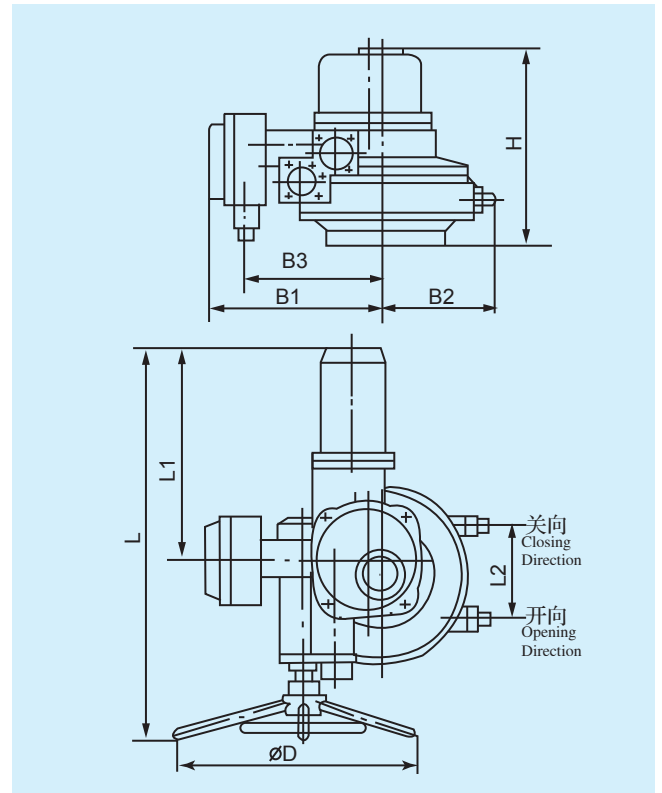
5.1.2 DQ, DQW, DQB Configuration and configuration size is shown in Drawing 3 and Tabulate 3

表3、DQW、DQB的外形尺寸
Tabulate 3. DQ, DQW, DQB Configuration size

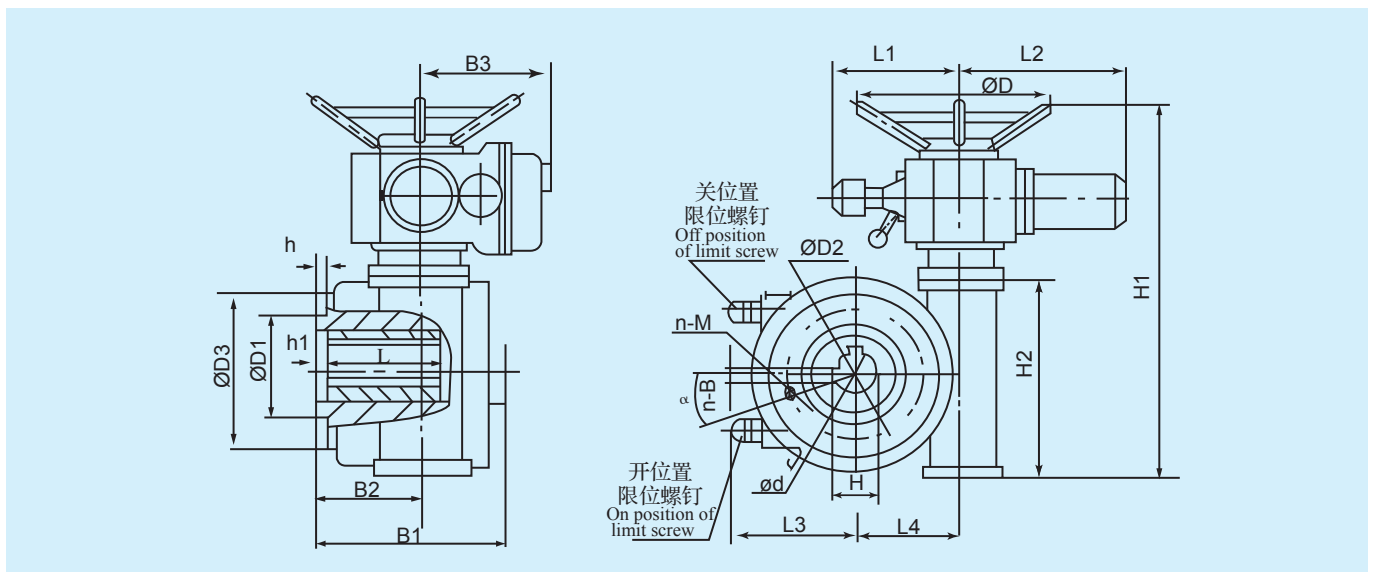
型号 Style	尺寸 Size	B1	B2	B3	H1	H2	L1	L2	L3	L4	φ D
DQW400		204	100	235	620	300	197	363	165	120	350
DQB400		204	100	232	620	300	197	363	165	120	350
DQW600		204	100	235	620	300	197	363	165	120	350
DQB600		204	100	232	620	300	197	363	165	120	350
DQW800		195	85	320	755	330	277	437	195	150	450
DQB800		195	85	378	755	330	277	437	195	150	450
DQW1000		195	85	320	755	330	277	437	195	150	450
DQW1200											
DQB1000		195	85	378	755	330	277	437	195	150	450
DQB1200											
DQW1600		252	125	320	915	400	277	437	265	180	450
DQB1600		252	125	378	915	400	277	437	265	180	450
DQW2000		252	125	325	946	400	283	526	265	180	500
DQB2000		252	125	412	946	400	283	526	265	180	500
DQW3200		310	150	325	1210	545	283	526	350	280	500
DQB3200		310	150	412	1210	545	283	526	350	280	500
DQW4000		310	150	342	1210	545	309	554	350	280	320
DQB4000		310	150	456	1210	545	309	554	350	280	320
DQW6300		390	190	342	1415	735	309	554	440	400	320
DQB6300		390	190	456	1415	735	309	554	440	400	320
DQW8000		390	190	342	1415	735	309	554	440	400	320

5.2、连接尺寸

5.2.1、QW、QB与阀门的连接型式和尺寸，见表4



5.2.2、DQW、DQB与阀门的连接尺寸见图3和表5

5.2.Connection size

5.2.1.Connected style and size of QW, QB with valve is shown in Tabulate 4

5.2.2.Connected style and size of DQ, DQW, DQB with valve is shown in Drawing 3 and Tabulate 5

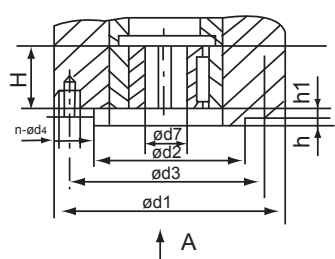
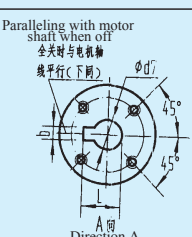
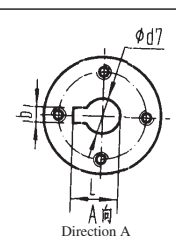
表 4 .QW、QB的连接尺寸
Tabulate 4 QW, QB connected size

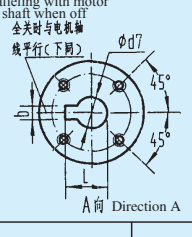
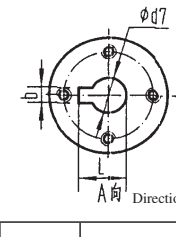
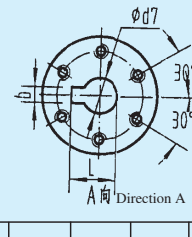
产品代号 Item No.	连接型式 Connecting Style	法兰螺孔型式尺寸 FLANGE THREADED HOLE STYLE/SIZE																	
		FA型 FA Style			FB型 FB Style			FC型 FC Style											
Q1 QB1																			
		尺寸代号 Size code 法兰型式 Flange style 法兰号 Flange No. 产品型号 Item No.			d1	d2 (f8)	d3	n-d4	d7			H	h	h1	b	L			
		FA	F05	Q5	65	35	50	4-M6		10	22	40	3	3	/	/			
				Q10															
			F07	Q20	90	55	70	4-M8	/	15	28	45							
		Q30																	
		FB	F10	Q30	125	70	102	4-M10			42								
				FB1	Q10	77	0	57	4-M6	12.8	10	22	40	0	3	3	14.2		
					Q20	92	0	70	4-M8	19	15	28	45	0		5	21.4		
		FB3	Q30	115	0	89	4-M12	22.8	18	28		0			24.5				
Q2 QB2																			
		尺寸代号 Size code 法兰型式 Flange style 法兰号 Flange No. 产品型号 Item No.			d1	d2 (f8)	d3	n-d4	d7			H	h	h1	b	L			
		FA	F10	Q60	125	70	102	4-M10		15	42	65	3	3	/	/			
				Q90	150	85	125	4-M12	/	20	50								
			F14	Q120	175	100	140	4-M16											
		FB	FB1	Q60	115	0	89	4-M12	28.6	20	42	0	3	8	31.9				
				Q90	140	0	108	4-M12	31.7						35				
			Q120																
			FB3					33.15											36.45
			FB4	Q120	197	0	159	4-M16	38.0								0		10
FB5						41.5						44.8							
FC	FC	Q60	170	110	140	6-M10	28			-7	3	8	31.3						
		Q90																	

续表 4

Tabulate 4

Q3 QB3																																																																																																																																																													
		<table border="1"> <tr> <td rowspan="2">法兰型式 Flange style</td> <td rowspan="2">法兰号 Flange No.</td> <td rowspan="2">尺寸代号 Size code Item No.</td> <td rowspan="2">d1</td> <td rowspan="2">d2 (f8)</td> <td rowspan="2">d3</td> <td rowspan="2">n-d4</td> <td colspan="3">d7</td> <td rowspan="2">H</td> <td rowspan="2">h</td> <td rowspan="2">h1</td> <td rowspan="2">b</td> <td rowspan="2">L</td> </tr> <tr> <td>标准尺寸 Standard size</td> <td>预留尺寸 Spare size</td> <td>最大尺寸 Max. size</td> </tr> <tr> <td rowspan="4">FA</td> <td rowspan="2">F14</td> <td>Q200</td> <td rowspan="2">175</td> <td rowspan="2">100</td> <td rowspan="2">140</td> <td rowspan="2">4-M16</td> <td rowspan="2"></td> <td rowspan="2"></td> <td rowspan="2"></td> <td rowspan="2">80</td> <td rowspan="2">3</td> <td rowspan="2">2</td> <td rowspan="2">/</td> <td rowspan="2">/</td> </tr> <tr> <td>Q250</td> </tr> <tr> <td rowspan="2">F16</td> <td>Q300</td> <td rowspan="2">210</td> <td rowspan="2">130</td> <td rowspan="2">165</td> <td rowspan="2">4-M20</td> <td rowspan="2">/</td> <td rowspan="2">20</td> <td rowspan="2">60</td> <td rowspan="2">100</td> <td rowspan="2"></td> <td rowspan="2"></td> <td rowspan="2"></td> <td rowspan="2"></td> </tr> <tr> <td>Q400</td> </tr> <tr> <td rowspan="2">F25</td> <td>Q500</td> <td>300</td> <td>200</td> <td>254</td> <td>8-M16</td> <td></td> <td></td> <td></td> <td></td> <td></td> <td></td> <td></td> <td></td> </tr> <tr> <td>Q500</td> <td></td> <td></td> <td></td> <td></td> <td></td> <td></td> <td></td> <td></td> <td></td> <td></td> <td></td> <td></td> </tr> <tr> <td rowspan="4">FB</td> <td rowspan="2">FB1</td> <td>Q250</td> <td rowspan="2">197</td> <td rowspan="2">0</td> <td rowspan="2">159</td> <td rowspan="2">4-M16</td> <td>38</td> <td rowspan="2">20</td> <td rowspan="2">60</td> <td rowspan="2">80</td> <td rowspan="2">0</td> <td rowspan="2">2</td> <td rowspan="2">10</td> <td>41.3</td> </tr> <tr> <td>41.3</td> <td>44.7</td> </tr> <tr> <td rowspan="2">FB3</td> <td>Q300</td> <td rowspan="2">275</td> <td rowspan="2">0</td> <td rowspan="2">216</td> <td rowspan="2">4-M20</td> <td rowspan="2">50.8</td> <td rowspan="2">30</td> <td rowspan="2">60</td> <td rowspan="2">100</td> <td rowspan="2">0</td> <td rowspan="2">2</td> <td rowspan="2">16</td> <td>55.2</td> </tr> <tr> <td>Q400</td> </tr> <tr> <td rowspan="4">FC</td> <td rowspan="2">FC1</td> <td>Q250</td> <td rowspan="2">170</td> <td rowspan="2">110</td> <td rowspan="2">140</td> <td rowspan="2">6-M10</td> <td rowspan="2">28</td> <td rowspan="2">20</td> <td rowspan="2">60</td> <td rowspan="2">80</td> <td rowspan="2">-6</td> <td rowspan="2">2</td> <td rowspan="2">8</td> <td>31.3</td> </tr> <tr> <td>Q250</td> <td></td> </tr> <tr> <td rowspan="2">FC2</td> <td>Q300</td> <td rowspan="2">215</td> <td rowspan="2">135</td> <td rowspan="2">165</td> <td rowspan="2">6-M16</td> <td rowspan="2">36</td> <td rowspan="2">20</td> <td rowspan="2">60</td> <td rowspan="2">80</td> <td rowspan="2">-6</td> <td rowspan="2">2</td> <td rowspan="2">7</td> <td>42</td> </tr> <tr> <td>Q400</td> <td></td> </tr> <tr> <td>FC3</td> <td>Q500</td> <td>300</td> <td>200</td> <td>254</td> <td>8-M16</td> <td>55</td> <td>30</td> <td>70</td> <td>110</td> <td>-6</td> <td>2</td> <td>16</td> <td>62.2</td> </tr> </table>	法兰型式 Flange style	法兰号 Flange No.	尺寸代号 Size code Item No.	d1	d2 (f8)	d3	n-d4	d7			H	h	h1	b	L	标准尺寸 Standard size	预留尺寸 Spare size	最大尺寸 Max. size	FA	F14	Q200	175	100	140	4-M16				80	3	2	/	/	Q250	F16	Q300	210	130	165	4-M20	/	20	60	100					Q400	F25	Q500	300	200	254	8-M16									Q500													FB	FB1	Q250	197	0	159	4-M16	38	20	60	80	0	2	10	41.3	41.3	44.7	FB3	Q300	275	0	216	4-M20	50.8	30	60	100	0	2	16	55.2	Q400	FC	FC1	Q250	170	110	140	6-M10	28	20	60	80	-6	2	8	31.3	Q250		FC2	Q300	215	135	165	6-M16	36	20	60	80	-6	2	7	42	Q400		FC3	Q500	300	200	254	8-M16	55	30	70	110	-6	2	16	62.2
		法兰型式 Flange style								法兰号 Flange No.	尺寸代号 Size code Item No.	d1						d2 (f8)	d3	n-d4			d7													H		h													h1		b	L																																																																																																							
标准尺寸 Standard size	预留尺寸 Spare size		最大尺寸 Max. size																																																																																																																																																										
FA	F14	Q200	175	100	140	4-M16				80	3	2	/	/																																																																																																																																															
		Q250																																																																																																																																																											
	F16	Q300	210	130	165	4-M20	/	20	60	100																																																																																																																																																			
		Q400																																																																																																																																																											
F25	Q500	300	200	254	8-M16																																																																																																																																																								
	Q500																																																																																																																																																												
FB	FB1	Q250	197	0	159	4-M16	38	20	60	80	0	2	10	41.3																																																																																																																																															
		41.3					44.7																																																																																																																																																						
	FB3	Q300	275	0	216	4-M20	50.8	30	60	100	0	2	16	55.2																																																																																																																																															
		Q400																																																																																																																																																											
FC	FC1	Q250	170	110	140	6-M10	28	20	60	80	-6	2	8	31.3																																																																																																																																															
		Q250																																																																																																																																																											
	FC2	Q300	215	135	165	6-M16	36	20	60	80	-6	2	7	42																																																																																																																																															
		Q400																																																																																																																																																											
FC3	Q500	300	200	254	8-M16	55	30	70	110	-6	2	16	62.2																																																																																																																																																

说明:

- 1)FA型法兰号为GB12223-89标准,它与国际标准ISO5211等同,建议用户优先选用,以便与国际接轨,便于产品打入国际市场。
- 2)FB和FC是为满足引进和特殊产品的配套。
- 3)表中“h”栏中“正数”表示凸止口,“0”表示平面,“负数”表示凹止口。
- 4)Q3、QB3中FC3螺孔的分布与FA中8螺孔的分布相同。

Note:

- 1)FA style flange is based on standard GB12223-89 and it's equal as international standard ISO5211. it's preferred for customer and for products easy competition in international market.
- 2)FB/FC style is especially for imported and special products.
- 3)The “Positive” column of “h” column inside the tabulate means protruding stop. “0” means horizontal, “Negative” means concave stop.
- 4)The threaded hole distribution of FC3 of Q3, QB3 is same as eight threaded hole of FA.

表5.DQW、DQB型电装的接口尺寸

Tabulate 5 Connecting size of DQ style electric actuator

型号 Style	尺寸 Size	法兰号 Flange No.	φ D1 (f8)	φ D2	φ D3	φ d(H9) 最大 Max.	h	h1	a °	单键或双键 Single or double key n-B × H × L	花键 Spline n-b × φ d1 × φ d2 × L	n-M
DQW DQB	400/600	F16	130	165	120	80	5	5	45°	1-22 × 85.4 × 95	8-8 × 42 × 48 × 95	4-M20
DQW DQB	800/1000	F25	200	254	300	100	5	5	22.5°	1-28 × 106.4 × 110	8-10 × 52 × 60 × 110	8-M16
DQW DQB	1600/2000	F30	230	298	350	120	5	5	22.5°	2-32 × 127.4 × 130	8-12 × 72 × 82 × 130	8-M20
DQW DQB	3200/4000	F35	260	356	415	160	5	5	22.5°	2-40 × 169.4 × 200	8-20 × 125 × 140 × 200	8-M30
DQW DQB	6300/8000	F40	300	406	475	180	5	5	22.5°	2-45 × 190.4 × 200	8-22 × 145 × 160 × 200	8-M36

注：法兰号为GB12223-89标准中的法兰号

Note: The flange No. is based on GB12223-89 standard

6. 电气控制原理和接线

6.1、QW、QB型电装的电气控制原理和接线。

6.1.1、QW的电控原理和接线见图4,电气元件见表6。

6.1.2、QB的电控原理和接线QB的电控原理与QW的相同，见图4。但QB的接线端子不一样，见图5。

6. Electric control theory and wiring

6.1.QW, QB style electric control theory and wiring.

6.1.1.QW style electric control theory and wiring is shown in Drawing 4. Electric component is shown in Tabulate 6.

6.1.2.QB style electric control theory and wiring. QB style electric control theory is same as QW which is shown in Drawing 4. But the QB connector is different which is shown in Drawing 5.



图4,QW电气原理和接线图、QW接线端子

Drawing 4 QW style electric control theory and wiring, QW connector

说明：

- 1)点划线框内的元件在电装内。
- 2)图中的序号即为端子号。
- 3)电机接D1、D2、D3，端子1、2、3不接。
- 4)如用户需要，本厂可提供4~20mA的标准信号。
- 5)可带现场点动按钮。

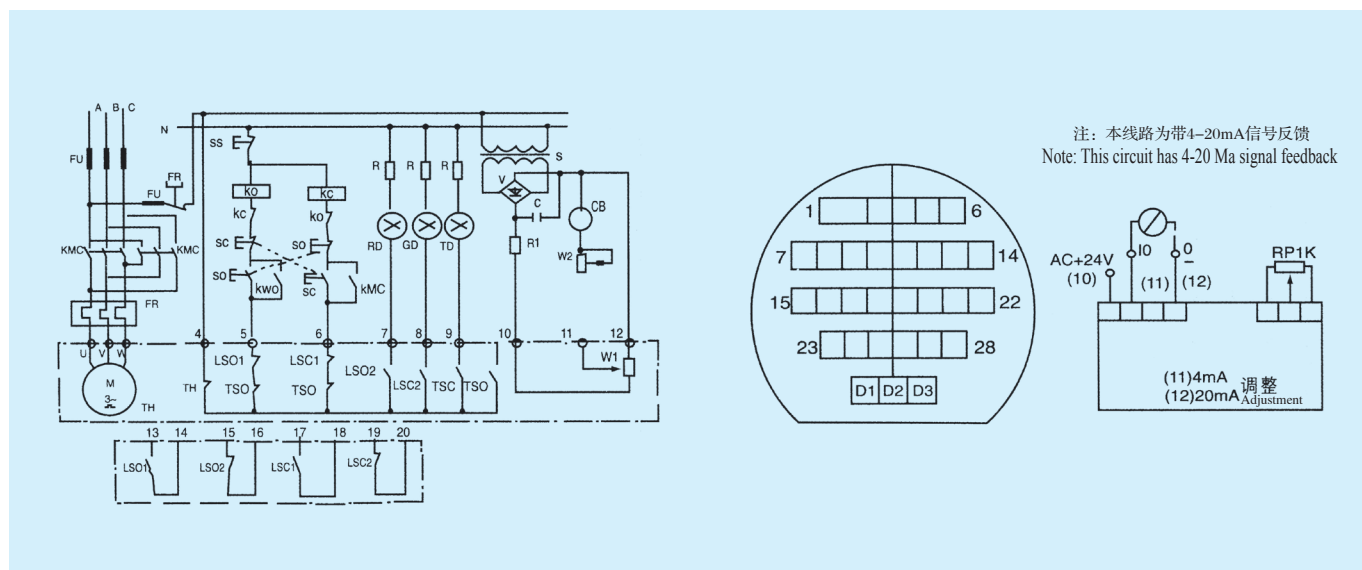
Note:

- 1)Component shown inside the dot-slash frame is inside the electric actuator.
- 2)The serial No. in the drawing is connector No.
- 3)Motor is connected with D1, D2, D3. No connection to 1,2,3.
- 4)We can supply standard 4-20mA signal as required.
- 5)The site dot activated button is available.

表6.电气元件表
Tabulate 6 Electric component list

代号 Code	名称 Description	型号 Item No.	数量 Quantity
RJ	热断路器 Thermal circuit breaker	JR1bB	1
TSO,TSC	转矩开关 Torsion switch	DK3-2或HWK-1	2
LSO,LSC	行程开关 Traveling switch	MK2-1	2
M	电动机 Motor	YDF	1
WD,RD,GD	指示灯 Indicator	ND3,NDL3	3
KMO,KMC	交流接触器 Alternating contactor	CJ10-	2
SO,SC	按钮 Button	LA11-11D	3
R	电阻 Resistance	68K,1/2W	4
B	变压器 Transformer	220V/9V/6V	1
V	二极管 Diode	2CP10	4
C	电解电容 Electrolytic capacity	220 μ F,10V	1
R1	电阻 Resistance	100 Ω 1/2W	1
W1	电位器 Potentiometer	100 Ω 3W	1
W2	电位器 Potentiometer	300 Ω 1/2W	1
CB	开度表 Open range indicator	0-10mA	1
FU	熔断器 Fuse	RL	
TH	温度开关 Temperature switch		1

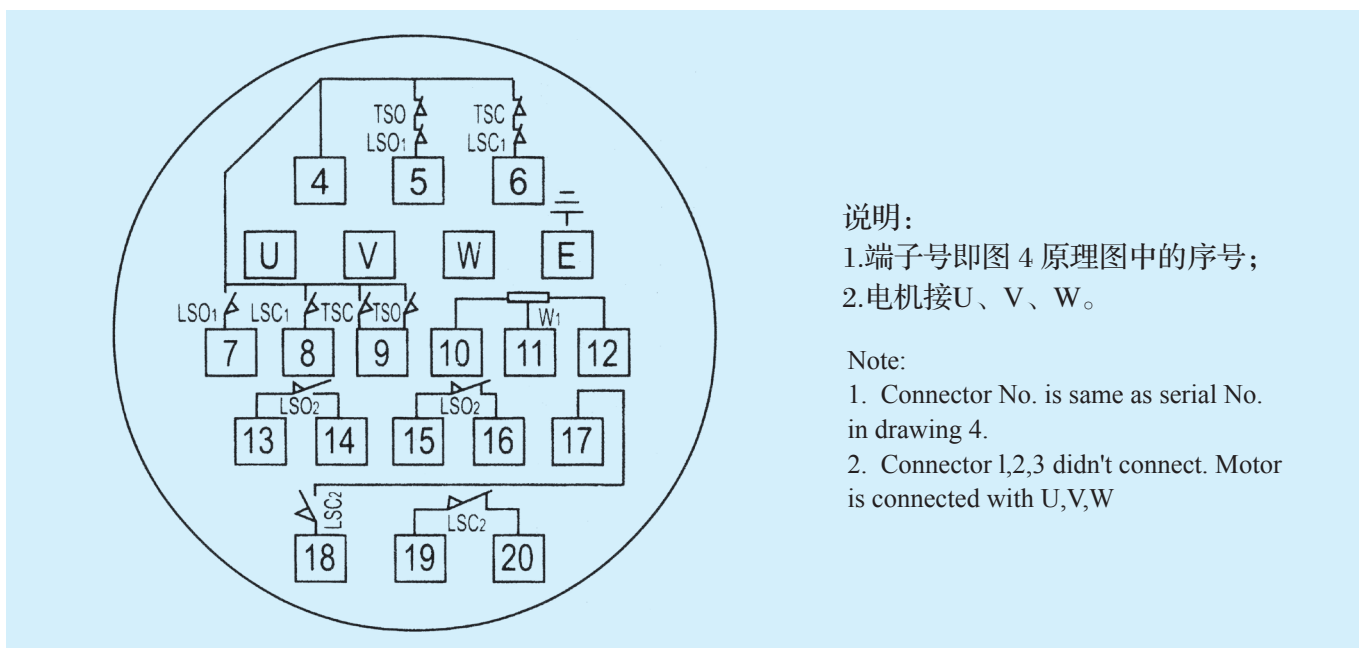

说明：
1.端子号即图 4 原理图中的序号；
2.电机接U、V、W。

Note:
1. Connector No. is same as serial No. in drawing 4.
2. Connector 1,2,3 didn't connect. Motor is connected with U,V,W

图5.QB防爆型接线端子
Drawing 5 QB explosion proof connector

接线时应按图6所示的方法，用弯头夹住电线。接线盒内不同电位导电零件之间的电气间隙应符合下列要求：电压220伏时不小于6mm；电压380伏时不少于8mm。接线盒内有两个引入装置，一个引入电动力线，一个引入控制线，使用的动力线必须有地线，并与接线盘上的接线端子E相接。引入导线直径规格见图7和表7。接好线后应装好密封圈。密封圈的邵氏硬度应为45~55度，损坏及老化应及时更换。

The wiring must follow Drawing 6. Clamp the wire by bend. The different electric gap between the potential conducting component shall following requirement: Not less than 6mm when 220V; Not less than 8mm when 380V. There are two drawing in device inside connecting box. One is for motor power wire and another is for control wire. The power wire must have ground wire and connected with connector E in connecting box. The diameter of drawing in is shown in Drawing 7 and Tabulate 7. The sealing ring is necessary after finish wiring. Shore hardness of sealing ring must be 45-55 degree and it must be changed when damaged or aged.



图6.端子接线方法
Drawing 6 Connector wiring method



图 7.密封圈
Drawing 7 Sealing ring

表7.电缆直径
Table 7 Cable diameter

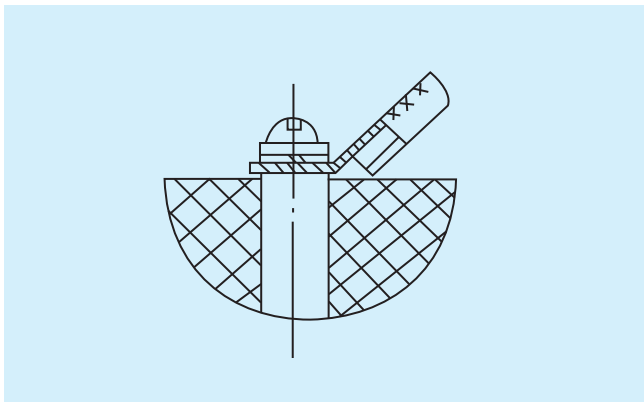
密封圈同心槽内孔直径 (mm) Inner diameter of sealing ring groove(mm)	$\varnothing 15$	$\varnothing 19$	$\varnothing 23$
允许引入电缆公称直径 (mm) Nominal diameter of drawing in cable(mm)	$\varnothing 15 \pm 1$	$\varnothing 19 \pm 1$	$\varnothing 23 \pm 1$

6.2、DQW、DQB的电控原理和接线

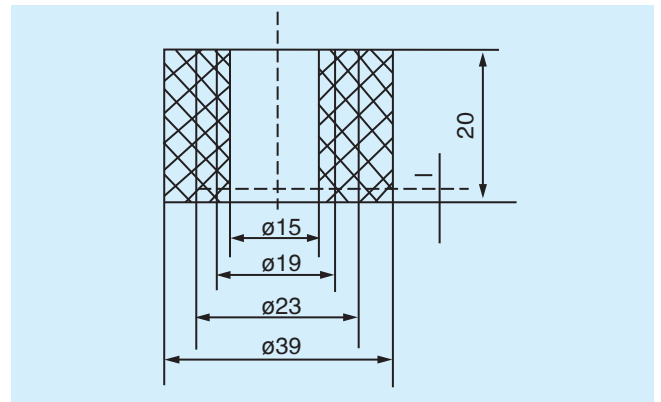
6.2.1、电气原理

DQW型电装由ZW型电装加二级减速装置组成，所以它的电控原理与ZW型电装相同。见图8

6.2.DQ, DQW, DQB electric control theory and wiring

6.2.1.Electric theory

DQ style electric actuator is based on Z style equipped with second reducer. The electric control theory is same as Z style. Please refer to Drawing 8.



图8①电气原理图
Drawing 8 1 Electric control theory



图8②开度表接线原理图
Drawing 8 2 Open range indicator wiring theory

图8②为开度表接线原理图，电装上无此线路，仅供用户参考使用，电气元件见表8。如用户需要，本厂可提供4~20mA的标准信号和现场点动按钮。

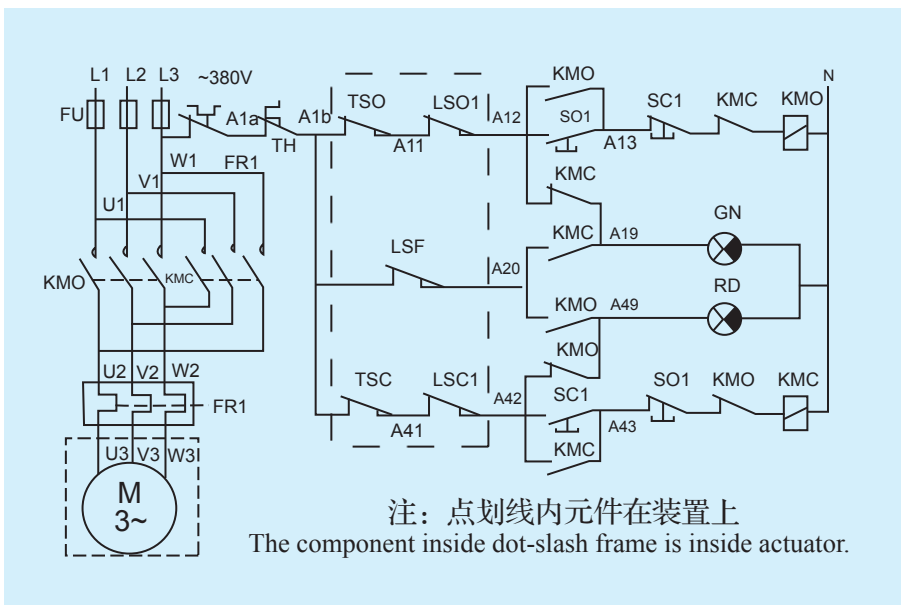
Drawing 8 ② is open range indicator wiring theory. There is no circuit in actuator and only as reference for customer. The electric component list is shown in Table 8. We can supply 4-20Ma standard signal and site dot activated button as required.

阀位的开度指示有远传开度指示和指示灯式开度指示两种，但远传开度指示和指示灯式开度指示不能同时使用。电装内电气元件的排列见图9。

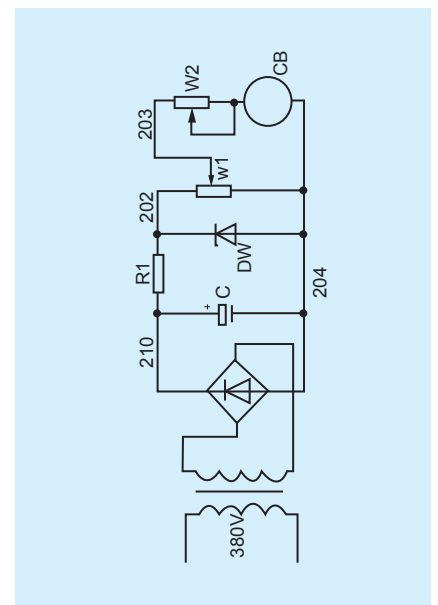
There are two opening direction for the opening of valve: remote opening direction and indication lamp opening direction however they cannot be used at the same time. Arrangement of electric components in the electric devices can be seen in Figure 9.



图9.电气原件位置图
Drawing 9 Electrical original location map

表8.电气原件表
Tabulate 8 Electric component list

代号 Code	名称 Description	型号 Item No.	数量 Quantity	备注 Remark
FR1	热继电器 Thermal relay		1	用户自备 Prepared by customer
FU1-FU3	熔断器 Fuse		3	用户自备 Prepared by customer
TSO TSC	转矩开关 Torsion switch	DK32	2	
LSO LSC	行程开关 Traveling switch	HWK - 22A	4	
LSF	闪光开关 Flash switch	V - 157	1	
W1	电位器 Potentiometer	WX10 - 1K	1	
KMO KMC	交流接触器 Alternating contactor	CJ10	2	用户自备 Prepared by customer
SO1 SC1	按钮 Button	LA11 - 11D	2	用户自备 Prepared by customer
M	电机 Motor	YDF2 - W	1	
TH	热敏开关 Temperature switch			特殊订货 Special order
RT	空间加热器 Space heater		1	特殊订货 Special order

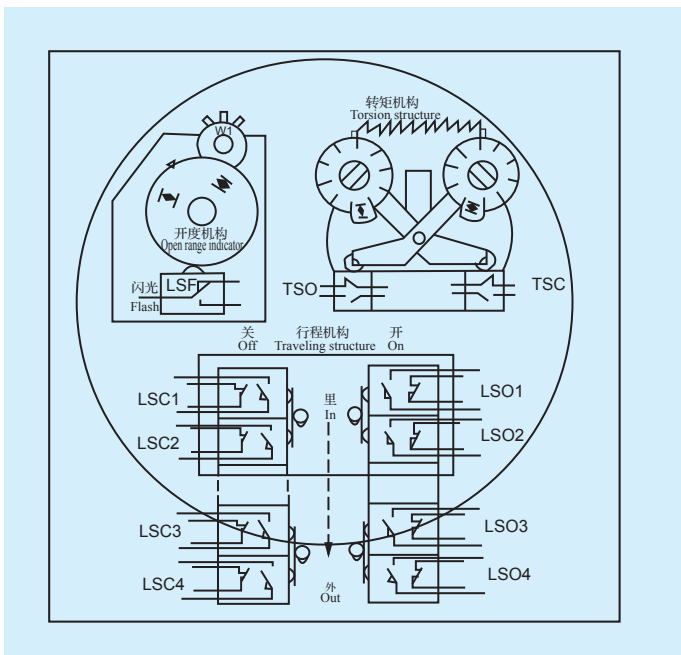

图10. ZW端子接线图
Drawing 10. ZW core connector wiring



图11. DQB防爆型端子接线图
Drawing 11. DQB explosion proof connector wiring

6.2.2.DQB的接线图见11

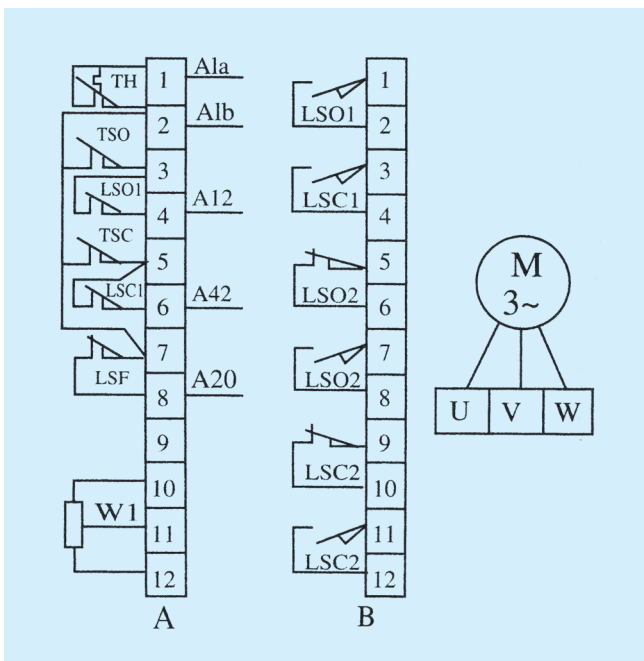
6.2.2.DQB wiring is shown in Drawing 11

7、安装和拆卸

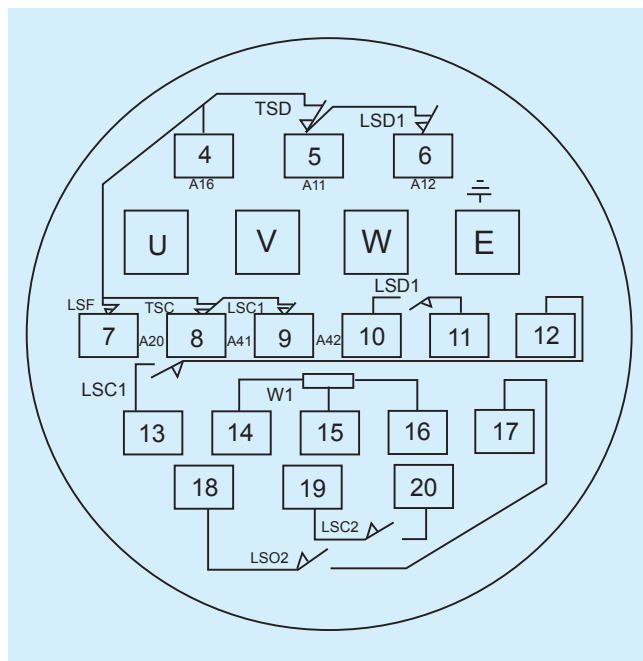
- 1)本装置的安装形式无原则要求，但电机处于水平状态，电气箱盖处于水平或垂直向上状态为推荐安装形式，这样有利于润滑、调试、维护和手动操作；
- 2)安装时应保证维修检查人员拆卸各部件所需的空间；
- 3)安装拆卸调试时不可损伤密封面、密封件和防爆电装的防爆面（见图1），并应在隔爆面上涂上防锈油。

8、使用注意事项

- 1)不得在爆炸环境下拆去电气箱盖带电调试电动装置，打开电气箱盖时，必须先切断电源；
- 2)开度机构窗不得与硬物碰撞；
- 3)不得在阴雨天于户外打开电气箱盖，电机等密封部位；
- 4)检查维修后，须将电气箱罩、电机及其它密封部位盖严紧固，以防雨水、潮气进入，造成电器元件失效及零件锈蚀。
- 5)安装或重装后，首次电动操作，必须使阀门处于中间位置检查开、关方向，必须按调试要求进行逐项调试，检查各部件正常后，才能投入使用。
- 6)本装置系采用阀门专用三相异步电动机，额定持续工作时间不得超过10分钟，安装调试时必须注意，以防电机过热。
- 7)当阀门很少使用时，应制订定期启动检查电动装置的制度。

9、调整

电动装置与阀门组装后，必须对转矩控制器、行程控制器、开度指示器分别进行调整，方可使用。

调整前，必须检查开度指示器上的电位器齿轮是否已脱开(把电位器齿轮的紧定螺钉松开即可)，以防损坏；检查电机的旋向，控制线路是否正确，以防电机失控。

9.1、QW、QB电装的调整

QW、QB电装的转矩控制器、行程控制器及开度指示器相同，故调整方法一样。

7.Installation and dis-installation

- 1)There is no special requirement for actuator installation style. We suggest motor in horizontal. Electric box cover in horizontal or vertical upward. It's helpful for lubrication, commissioning, maintenance and manual operation.
- 2)There should leave necessary space for maintenance person to dis-assembly every component.
- 3)Please don't damage the sealing surface, sealing component and explosion proof wall (Shown in Drawing 1) of explosion proof device when dis-assembly or maintenance. Please also cover stain proof oil on explosion proof wall.

8. Cautions

- 1)Please don't remove electric box cover and test the electric actuator with electricity under explosive environment. Please cut off power before open electric box cover.
- 2)The open range indicator window can't touch hard material.
- 3)Please don't remove electric box cover and motor sealing position outdoors in rainy weather.
- 4)Please cover the electric box cover, motor and other sealing position tightly after maintenance to prevent rain and humidity to cause electric component bad or stain.
- 5)Please check valve on/off direction when it's in middle position for first time power operation after installation or re-installation. Please follow the adjustment requirement step by step. It can only come into use after every component is verified normal.
- 6)The three phase asynchronization motor is equipped in the actuator and the nominal continuous operation period shall be less than 10 minutes. Please pay special attention to it to prevent motor over heat.
- 7)The regular start and inspection measures must be taken when valve is seldom in operation.

9.Adjustment

After the electric device is equipped with valve, adjustment must be carried out for torsion control unit, traveling control unit and open range indicator respectively.

Before adjustment, please check if the potentiometer gear of open range indicator is loosen (Loosen the screw of potentiometer gear is OK) to prevent possible damage. Also, check the motor rotary direction and control circuit to prevent motor out of control.

9.1.QW, QB adjustment

They have the same torsion control unit, traveling control unit and open range indicator. And the y share the same adjustment.



图12.力矩控制器

Drawing 12 The torsion control unit

9.1.1、力矩控制器的调整

力矩控制器的结构见图12，力矩控制器在出厂前已根据订货要求调整好，并填在产品合格证上，一般不需再调整。若需调整，只要松开螺钉7，微微拨动开、关向凸轮，再将螺钉固紧，先调关向，后调开向。

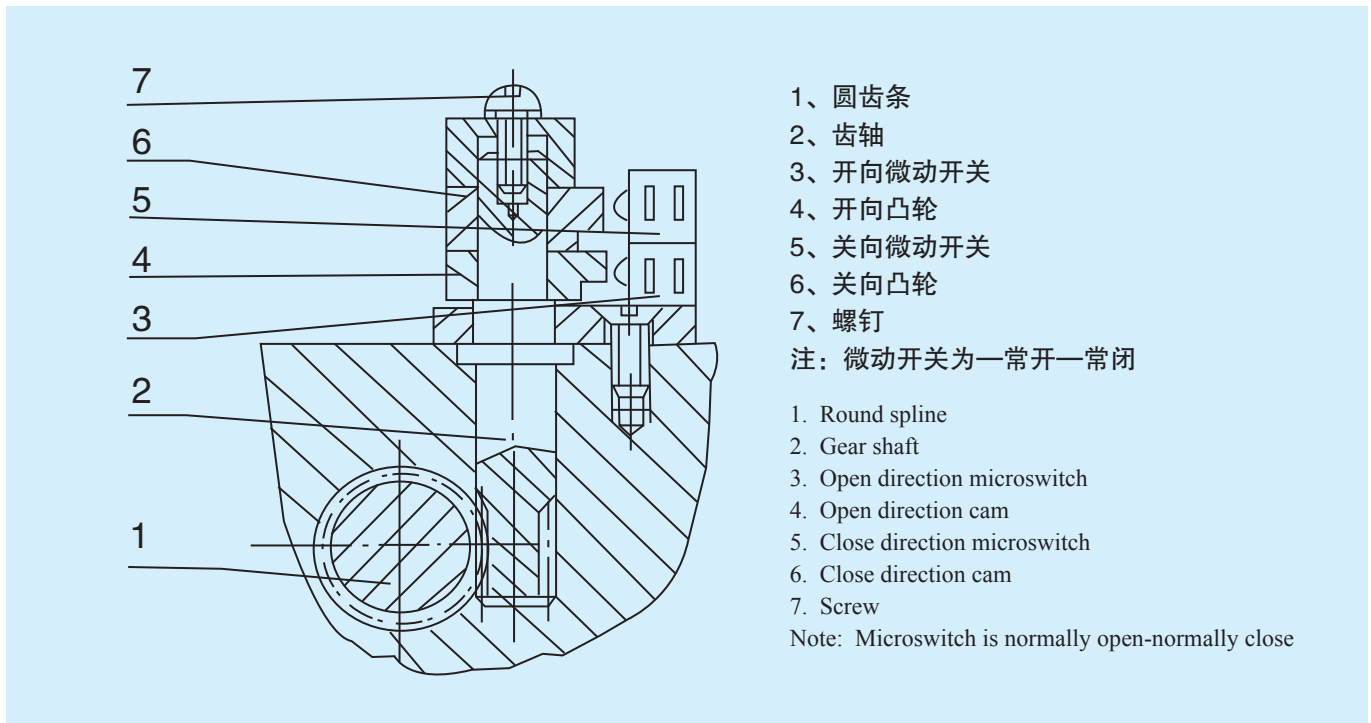
9.1.2、行程控制器和开度指示器的调整

行程控制器和开度指示器的结构见图13，调整前必须松开电位器齿轮的紧定螺钉。

9.1.2.1、行程控制器的调整

- 1)转动手轮使阀门“全关”；
- 2)松开输出轴上的螺钉，顺时针转动关向凸轮，使其刚好压动关向微动开关，再拧紧螺钉；
- 3)手动开阀至中间位置，电动关阀，检查阀门关闭是否符合要求，如不符合要求，按上述方法微调关向凸轮，直到符合要求为止；
- 4)手动开阀至全开位置，松开螺钉，逆时针转动开向凸轮，使其刚好压动开向微动开关，再拧紧螺钉；
- 5)手动或电动关阀，电动开阀，检查阀门开启是否符合要求，如不符合要求，按步骤4)微调开向凸轮，直至符合要求为止；

9.1.1.Torsion control unit adjustment

The torsion control unit structure is shown in Drawing 12. The torsion control unit is finished adjustment by order requirement before delivery to customer and shown in quality certificate. No necessary to carry out adjustment again. If the adjustment must be carried out, loosen the screw 7, slightly touch open/close direction cam then tighten the screw. First adjust close direction, then adjust open direction.

9.1.2.Traveling control unit and open range indicator adjustment.

Traveling control unit and open range indicator structure is shown in Drawing 13. The tighten screw of potentiometer gear must be loosen before adjustment.

9.1.2.1.Traveling control unit adjustment.

- 1)Turn the hand wheel and make valve "Complete closed".
- 2)Loosen the output shaft screw and turn close direction cam clockwise so that it just press close microswitch. Then tighten the screw.
- 3)Turn on the valve to middle position by hand and turn off valve by power. Check if the valve close meeting requirement. If the close can't meet the requirement, please slightly adjust close direction cam till OK.
- 4)Turn on the valve to complete open position by hand, loose the screw and turn cam anti-clockwise so that it just press close microswitch. Then tighten the screw.
- 5)Turn off the valve by hand or power. Turn on the valve by power and check if the valve open meeting requirement. If the open can't meet the requirement, please slightly adjust open direction cam till OK.

9.1.2.2、现场开度指示器的调整

参见图13，把阀门关到全关位置，松开输出轴上的螺钉，转动刻度盘，使刻度盘上的“O”位对准指针，再拧紧螺钉。

9.1.2.2.Site open range indicator adjustment

Turn off the valve till complete off position following Drawing 13. Loose the screw in output shaft, turn the dial till the "0" position aiming at finger. Then tighten the screw.



图13、Q、QB行程控制器和开度指示器
Drawing 13 Q,QB Traveling control unit and open range indicator

9.1.2.3、电位器的调整

参见图17，手动或电动关闭阀门，面对电位器，逆时针转动电位器小轴至终端位置，然后拧紧电位器齿轮上的紧定螺钉即可。

9.1.2.3 Potentiometer adjustment

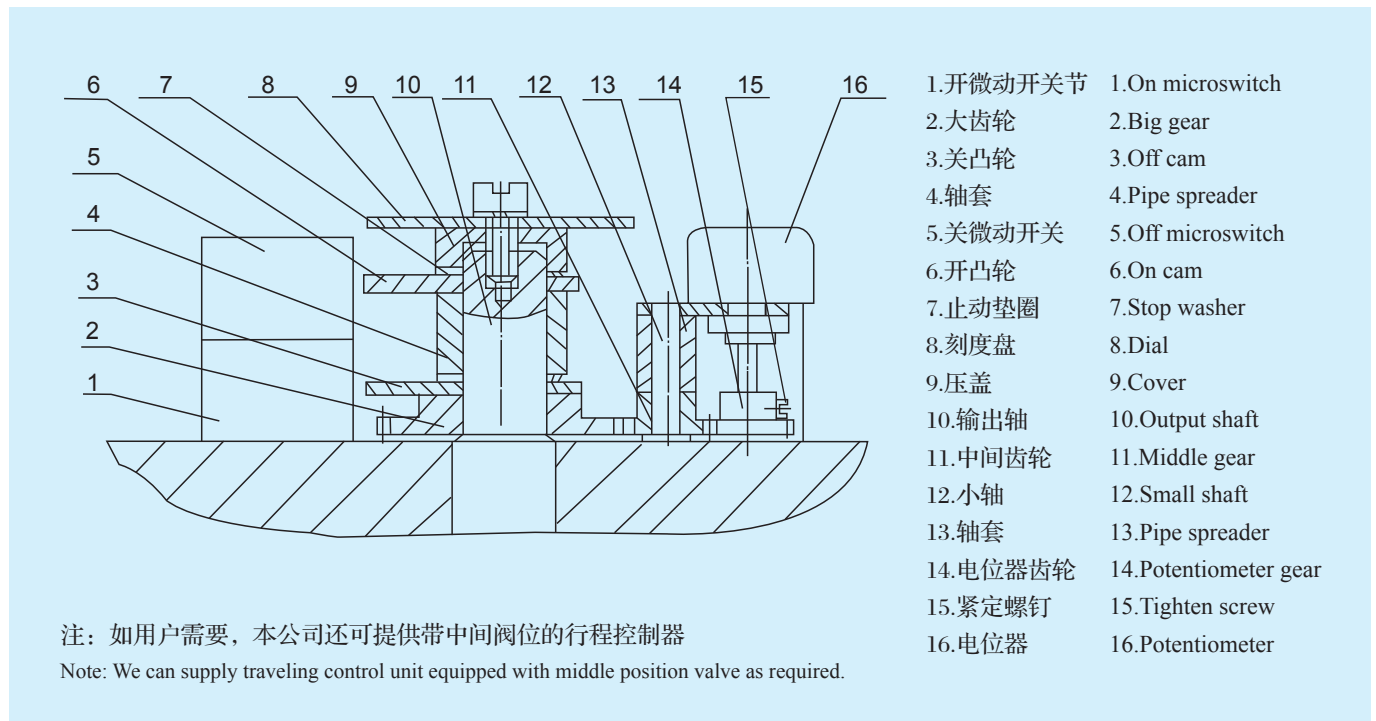
Turn off the valve by hand or power following Drawing 17. Turn the small shaft of potentiometer anti-clockwise facing potentiometer. Then tighten the screw of potentiometer gear.

9.2、DQ、DQW、DQB的调整

9.2.DQ,DQW, DQB adjustment

DQ、DQW、DQB电装的转矩控制器、行程控制器及开度指示器结构原理相同,故调整方法一样。

DQ,DQW, DQB have same torsion control unit, traveling control unit and open range indicator. And they share the same adjustment.

9.2.1、转矩控制器的调整

9.2.1.Torsion control unit adjustment.

转矩控制器的结构见图14，出厂时已按用户调整好转矩，一般不需调整，如需改变整定值，可按下列方法调整：旋转凸轮的调整轴至所需的刻度，先调关向，再调开向。

Torsion control unit structure is shown in Drawing 14. The torsion is finished adjustment before delivery. If the set up must be changed, please carry out as below: Turn the cam adjustment shaft till requirement. First adjust close direction then open direction.

9.2.2、行程控制器的调整

9.2.2.Traveling control unit adjustment

行程控制器的结构见图15。调整方法如下：

Traveling control unit structure is shown in Drawing 15. Adjustment as below:



图14、DQ、DQW、DQB 型电装的转矩控制器
 Drawing 14 DQ, DQW, DQB style torsion control unit



图15、行程控制器
 Figure 15 Control of Stroke

9.2.2.1、全关位置的调整

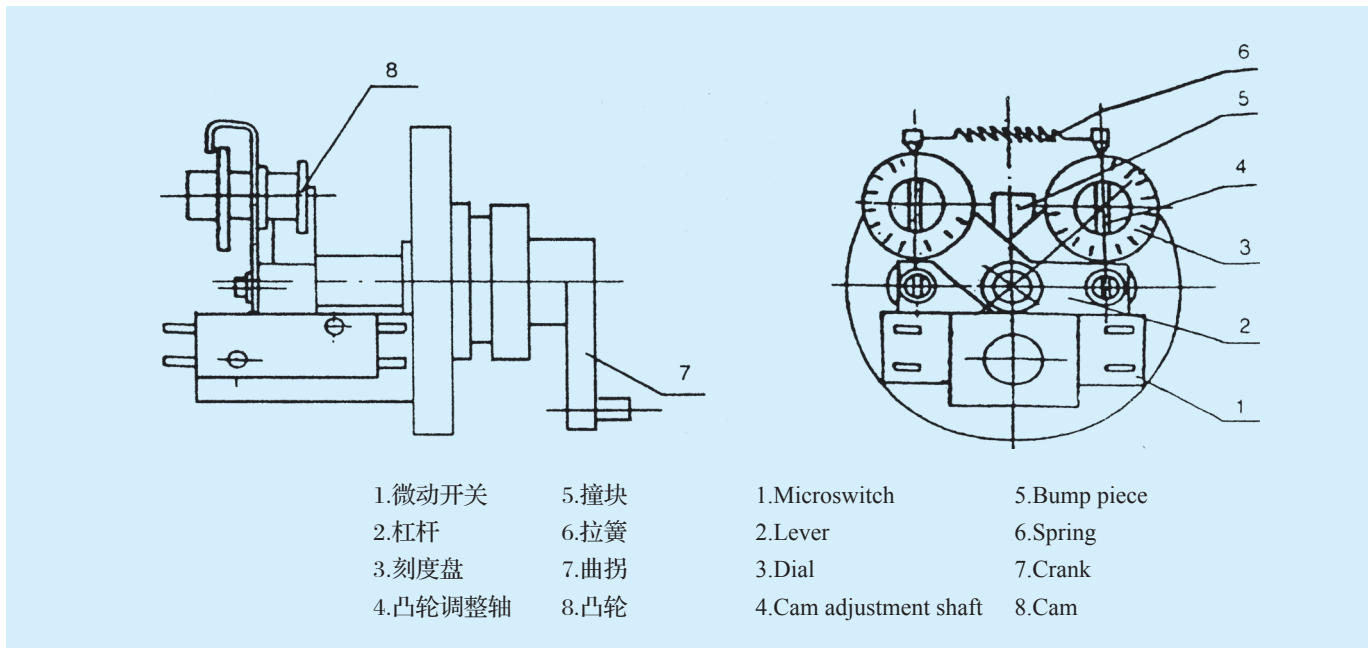
- a) 用手动将阀门关严；
- b) 用螺丝刀压下顶杆并转90°卡住；
- c) 按关向箭头旋转关向调整轴，直到关和凸轮动作为止；
- d) 旋回顶杆至原来的位置。

9.2.2.1.Complete close position adjustment

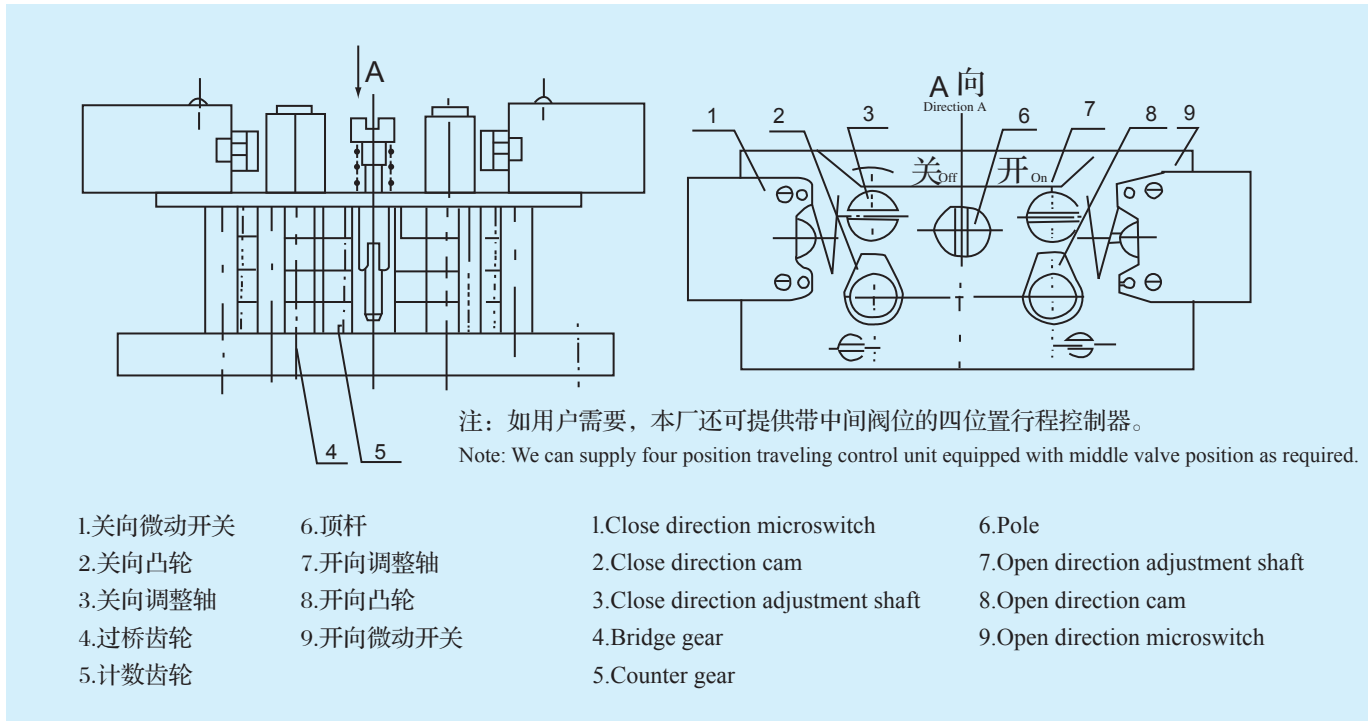
- a) Close valve tightly by hand.
- b) Press the pole by screwdriver and turn 90 degree to stop.
- c) Turn close direction adjustment shaft following arrow till close direction cam stop.
- d) Turn the pole to former position.

9.2.2.2、全开位置的调整

- a) 用手动将阀门开到所需的位置；
- b) 压下顶杆并转90°卡住；
- c) 按开向箭头旋转开向调整轴，直到开向凸轮动作为止；
- d) 旋回顶杆至原来的位置。

9.2.3、位置指示器的调整

位置指示器的结构见图16，在调整好转矩、行程的基础上高速现场开度指示器和远传电位器，调整前必须先将电位器齿轮脱开，调整方法如下：

- a) 移动转圈数调整齿轮至所需的转圈数位置；
- b) 手动或电动关闭阀门；
- c) 转动关指示盘使关向标志对准指针；
- d) 用钳子夹住电位器转轴，面对刻度盘，逆时针转动电位器轴接近终端位置，然后拧紧电位器齿轮的紧定螺钉；
- e) 电动或手动操作阀门至全开位置，保持关向刻度盘不动，转动开指示盘使开向标志对准指针；
- f) 电动操作阀门检查闪光灯，阀门开的过程中红灯闪光，全开时红灯长亮；阀门关闭过程中绿灯闪光，关到位时绿灯长亮。

9.2.2.2.Complete open position adjustment

- a) Turn the valve till required position by hand
- b) Press the pole and turn 90 degree to stop
- c) Turn open direction adjustment shaft following arrow till open direction cam stop
- d) Turn the pole to former position

9.2.3.Position indicator adjustment

Position indicator structure is shown in Drawing 16. Open range indicator and remote transmission potentiometer based on finishing torsion and traveling adjustment. Please make sure loose the potentiometer gear before adjustment. Adjustment as below:

- a) Move the moving-coil adjustment gear till required position
- b) Close valve by hand or power
- c) Turn the close indicator dial to make the close mark aiming at finger
- d) Clamp the potentiometer rotary shaft, turn the potentiometer shaft anti-clockwise facing the dial till near end position. Then tighten the screw of potentiometer gear.
- e) Operate the valve to complete open position by hand or power and keep dial still. Turn open dial to make the open mark aiming at the finger.
- f) Operate the valve by power and check the flash. The red light will flash during valve opening process and keeps on when valve complete open. The green light will flash during valve close process and keeps on when complete close.



图16、位置指示器
Drawing 16 Position indicator

10、故障及排除方法

10.Breakdown and elimination

序号 S/N	故障 Breakdown	原因 Reason	排除方法 Solution
1	电机不起动 Motor won't start	1.电源线脱开 2.控制线路故障 3.行程或力矩机构失灵 1. Power off 2. Control circuit breakdown 3. Traveling or torsion unit wrong	1.检查电源线 2.排除线路故障 3.排除行程或力矩机构故障 1. Check power wire 2. Resolve circuit problem 3. Resolve traveling or torsion unit problem
2	输出轴旋向不符合规定 Wrong output rotary direction	电源相序接反 Wrong power phase	调换任意两根电源线 Exchange any two power wire
3	电机过热 Motor overheat	1.连续工作时间太长 2.电机与电装不配套 3.一相断开 1. Too long continuous operation 2. Motor didn't fit with actuator 3. One phase break	1.停止运行，使电机冷却 2.检查配套情况 3.检查电源线 1. Stop operation and cool down motor 2. Check kit 3. Check power wire
4	运行中电机停转 Motor stop during operation	1.电装过载力矩控制器动作 2.阀门有故障 1. Overload torsion control unit start 2. Valve breakdown	1.增大整定力矩 2.检查阀门 1. Increase setting torsion 2. Check valve
5	阀门到位后电机不停转 或灯不亮 The motor keeps running or light off when valve reach position	1.行程或力矩机构有故障 2.行程控制器调整不当 1. Traveling or torsion unit wrong 2. Wrong traveling control unit adjustment	1.检查行程或力矩控制机构 2.重调行程控制器机构 1. Check traveling or torsion unit 2. Re-adjust traveling control unit
6	远方无阀位信号 No remote valve signal	1.远传电位器故障 2.电位器齿轮紧定螺钉松动 1. Remote potentiometer breakdown 2. Loosen screw of potentiometer gear	1.检查更换电位器 2.拧紧电位器齿轮紧定螺丝 1. Check and change the potentiometer 2. Tighten the screw of potentiometer gear

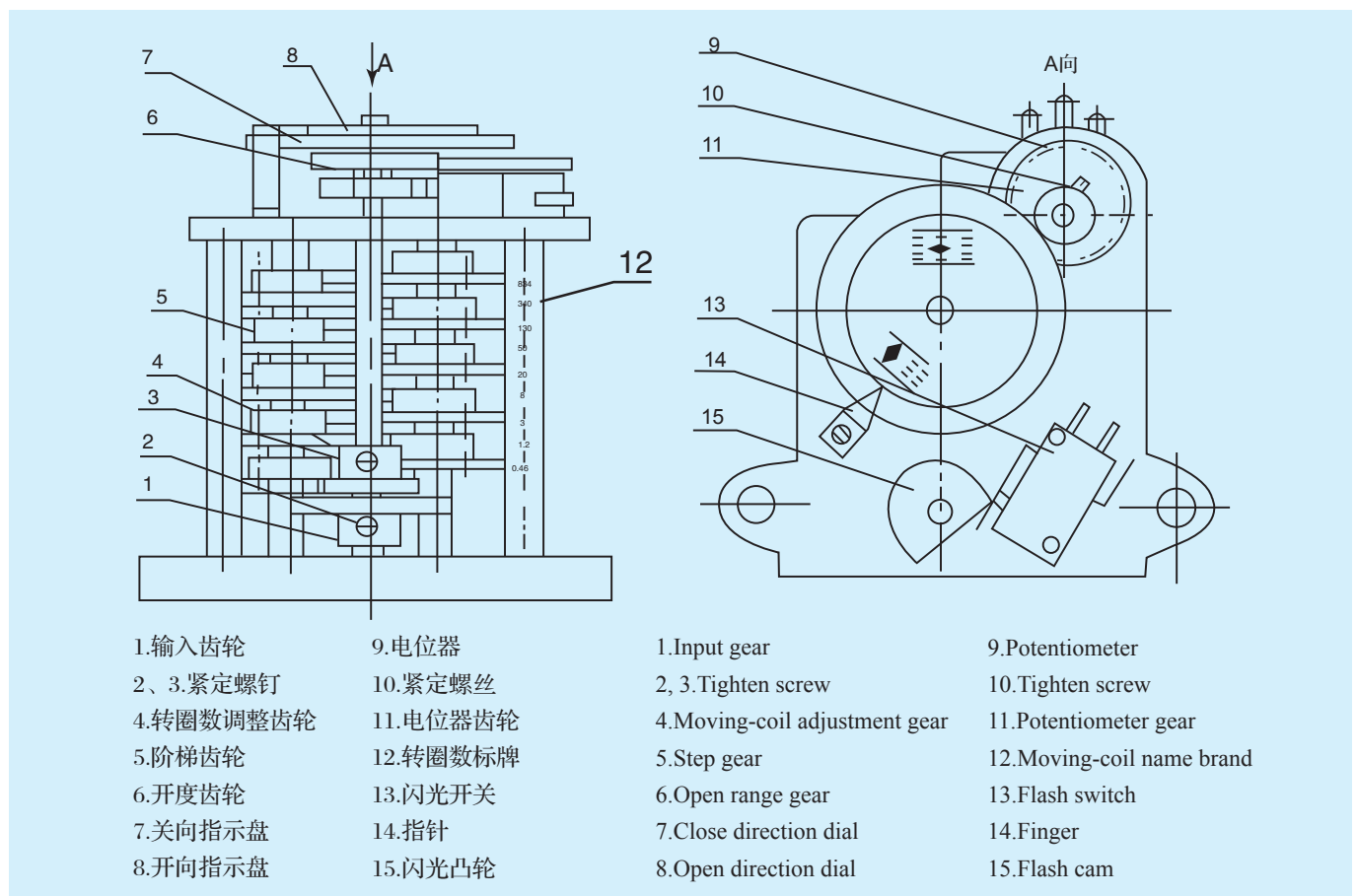
11、订货须知

- 1)请按型号表示方法写明型号，额定转矩，输出转速，防护类型。DQW型还应写明接线端子型式。
- 2)本装置一般按手轮顺时针旋转为关阀调整出厂，若与此相反需加以说明。
- 3)阀门电动装置的规格一般由用户选择。如用户要我厂协助选订本装置，需提供以下资料：
 - ①阀门种类、型号规格，接口尺寸；
 - ②介质状态，如湿度，压力等。
- 4)我厂还可按用户要求，提供特殊转速的电动装置。

11.Order

- 1)Please following the Style explanation to inform clearly: Nominal torsion, output rotary speed, protection type. The connector type is necessary for DQW style.
- 2)The actuator setting up is hand wheel turning clockwise for close direction before delivery. The opposite direction need pre-information.
- 3)The customer shall decide electric actuator specification. If customer need us to help choose the electric actuator, please offer following information
 - ①Valve style, specification, connector size.
 - ②Media state, for example humidity, pressure and so on.
- 4)The special rotary speed actuator is available as required.



常州市精迪阀门控制有限公司
Changzhou Jingdi Valve Control Co. Ltd.

地址：江苏省常州市横山桥镇芙蓉工业园区

邮编：213118

电话：(0519) 88661048

传真：(0519) 88661228

<http://www.jing-di.com>

E-mail: jdfm1048@126.com

Address: Furong Industrial Park, Hengshanqiao Town,
Changzhou, Jiangsu, China

Zip Code: 213118

Tel: (0519) 88661048

Fax: (0519) 88661228

